

User's Manual

CAUTION Do not connect this device to a computer data or telecommunications network.

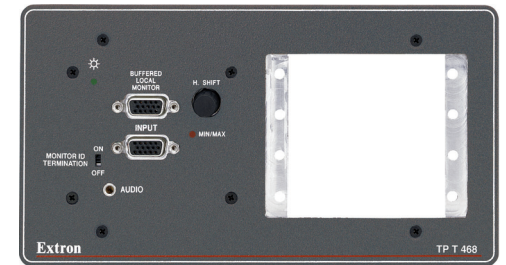

TPT BNC DA4



TP T 468

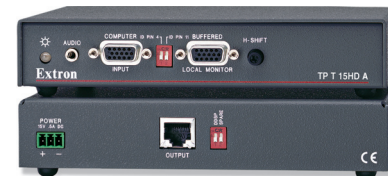

TP T 15HD A



TP T 15HD AV

TP Transmitters Family

High Resolution Video, Composite Video, and Stereo Audio
Twisted Pair Cable Transmission Products

68-546-03 Rev. G
07 08



www.extron.com

Extron Electronics, USA
1230 South Lewis Street
Anaheim, CA 92805
800.633.9876 714.491.1500
FAX 714.491.1517

Extron Electronics, Europe
Beeldschermweg 6C
3821 AH Amerfoort, The Netherlands
+800.3987.6673 +31.33.453.4040
FAX +31.33.453.4050

Extron Electronics, Asia
135 Joo Seng Rd. #04-01
PM Industrial Bldg., Singapore 368363
+800.7339.8766 +65.6383.4400
FAX +65.6383.4664

Extron Electronics, Japan
Kyodo Building, 16 Ichibancho
Chiyoda-ku, Tokyo 102-0082
Japan
+81.3.3511.7655 FAX +81.3.3511.7656

Precautions

Safety Instructions • English

 This symbol is intended to alert the user of important operating and maintenance (servicing) instructions in the literature provided with the equipment.

 This symbol is intended to alert the user of the presence of uninsulated dangerous voltage within the product's enclosure that may present a risk of electric shock.

Caution

Read Instructions • Read and understand all safety and operating instructions before using the equipment.

Retain Instructions • The safety instructions should be kept for future reference.

Follow Warnings • Follow all warnings and instructions marked on the equipment or in the user information.

Consignes de Sécurité • Français

 Ce symbole sert à avertir l'utilisateur que la documentation fournie avec le matériel contient des instructions importantes concernant l'exploitation et la maintenance (réparation).

 Ce symbole sert à avertir l'utilisateur de la présence dans le boîtier de l'appareil de tensions dangereuses non isolées posant des risques d'électrocution.

Attention

Lire les instructions • Prendre connaissance de toutes les consignes de sécurité et d'exploitation avant d'utiliser le matériel.

Conservser les instructions • Ranger les consignes de sécurité afin de pouvoir les consulter à l'avenir.

Respecter les avertissements • Observer tous les avertissements et consignes marqués sur le matériel ou présents dans la documentation utilisateur.

Eviter les pièces de fixation • Ne pas utiliser de pièces de fixation ni d'outils non recommandés par le fabricant du matériel car cela risquerait de poser certains dangers.

Sicherheitsanleitungen • Deutsch

 Dieses Symbol soll dem Benutzer in der im Lieferumfang enthaltenen Dokumentation besonders wichtige Hinweise zur Bedienung und Wartung (Instandhaltung) geben.

 Dieses Symbol soll den Benutzer darauf aufmerksam machen, daß im Inneren des Gehäuses dieses Produktes gefährliche Spannungen, die nicht isoliert sind und die einen elektrischen Schock verursachen können, herrschen.

Achtung

Lesen der Anleitungen • Bevor Sie das Gerät zum ersten Mal verwenden, sollten Sie alle Sicherheits- und Bedienungsanleitungen genau durchlesen und verstehen.

Aufbewahren der Anleitungen • Die Hinweise zur elektrischen Sicherheit des Produktes sollten Sie aufbewahren, damit Sie im Bedarfsfall darauf zurückgreifen können.

Befolgen der Warnhinweise • Befolgen Sie alle Warnhinweise und Anleitungen auf dem Gerät oder in der Benutzerdokumentation.

Keine Zusatzgeräte • Verwenden Sie keine Werkzeuge oder Zusatzgeräte, die nicht ausdrücklich vom Hersteller empfohlen wurden, da diese eine Gefahrequelle darstellen können.

Instrucciones de seguridad • Español

 Este símbolo se utiliza para advertir al usuario sobre instrucciones importantes de operación y mantenimiento (o cambio de partes) que se desean destacar en el contenido de la documentación suministrada con los equipos.

 Este símbolo se utiliza para advertir al usuario sobre la presencia de elementos con voltaje peligroso sin protección aislante, que puedan encontrarse dentro de la caja o alojamiento del producto, y que puedan representar riesgo de electrocución.

Precaucion

Leer las instrucciones • Leer y analizar todas las instrucciones de operación y seguridad, antes de usar el equipo.

Conservar las instrucciones • Conservar las instrucciones de seguridad para futura consulta.

Obedecer las advertencias • Todas las advertencias e instrucciones marcadas en el equipo o en la documentación del usuario, deben ser obedecidas.

Evitar el uso de accesorios • No usar herramientas o accesorios que no sean específicamente recomendados por el fabricante, ya que podrían implicar riesgos.

Avoid Attachments • Do not use tools or attachments that are not recommended by the equipment manufacturer because they may be hazardous.

Warning

Power sources • This equipment should be operated only from the power source indicated on the product. This equipment is intended to be used with a main power system with a grounded (neutral) conductor. The third (grounding) pin is a safety feature, do not attempt to bypass or disable it.

Power disconnection • To remove power from the equipment safely, remove all power cords from the rear of the equipment, or the desktop power module (if detachable), or from the power source receptacle (wall plug).

Power cord protection • Power cords should be routed so that they are not likely to be stepped on or pinched by items placed upon or against them.

Servicing • Refer all servicing to qualified service personnel. There are no user-serviceable parts inside. To prevent the risk of shock, do not attempt to service this equipment yourself because opening or removing covers may expose you to dangerous voltage or other hazards.

Slots and openings • If the equipment has slots or holes in the enclosure, these are provided to prevent overheating of sensitive components inside. These openings must never be blocked by other objects.

Lithium battery • There is a danger of explosion if battery is incorrectly replaced. Replace it only with the same or equivalent type recommended by the manufacturer. Dispose of used batteries according to the manufacturer's instructions.

Avertissement

Alimentations • Ne faire fonctionner ce matériel qu'avec la source d'alimentation indiquée sur l'appareil. Ce matériel doit être utilisé avec une alimentation principale comportant un fil de terre (neutre). Le troisième contact (de mise à la terre) constitue un dispositif de sécurité: n'essayez pas de la contourner ni de la désactiver.

Déconnexion de l'alimentation • Pour mettre le matériel hors tension sans danger, déconnectez tous les cordons d'alimentation de l'arrière de l'appareil ou du module d'alimentation de bureau (s'il est amovible) ou encore de la prise secteur.

Protection du cordon d'alimentation • Acheminer les cordons d'alimentation de manière à ce que personne ne risque de marcher dessus et à ce qu'ils ne soient pas écrasés ou pincés par des objets.

Réparation-maintenance • Faire exécuter toutes les interventions de réparation-maintenance par un technicien qualifié. Aucun des éléments internes ne peut être réparé par l'utilisateur. Afin d'éviter tout danger d'électrocution, l'utilisateur ne doit pas essayer de procéder lui-même à ces opérations car l'ouverture ou le retrait des couvercles risquent de l'exposer à de hautes tensions et autres dangers.

Fentes et orifices • Si le boîtier de l'appareil comporte des fentes ou des orifices, ceux-ci servent à empêcher les composants internes sensibles de surchauffer. Ces ouvertures ne doivent jamais être bloquées par des objets.

Lithium Batterie • Il y a danger d'explosion s'il y a remplacement incorrect de la batterie. Remplacer uniquement avec une batterie du même type ou d'un type équivalent recommandé par le constructeur. Mettre au rebut les batteries usagées conformément aux instructions du fabricant.

Vorsicht

Stromquellen • Dieses Gerät sollte nur über die auf dem Produkt angegebene Stromquelle betrieben werden. Dieses Gerät wurde für eine Verwendung mit einer Hauptstromleitung mit einem geerdeten (neutralen) Leiter konzipiert. Der dritte Kontakt ist für einen Erdschluß, und stellt eine Sicherheitsfunktion dar. Diese sollte nicht umgangen oder außer Betrieb gesetzt werden.

Stromunterbrechung • Um das Gerät auf sichere Weise vom Netz zu trennen, sollten Sie alle Netzkabel aus der Rückseite des Gerätes, aus der externen Stromversorgung (falls dies möglich ist) oder aus der Wandsteckdose ziehen.

Schutz des Netzkabels • Netzkabel sollten stets so verlegt werden, daß sie nicht im Weg liegen und niemand darauf treten kann oder Objekte darauf- oder unmittelbar dagegen gestellt werden können.

Wartung • Alle Wartungsmaßnahmen sollten nur von qualifiziertem Servicepersonal durchgeführt werden. Die internen Komponenten des Gerätes sind wartungsfrei. Zur Vermeidung eines elektrischen Schocks versuchen Sie in keinem Fall, dieses Gerät selbst öffnen, da beim Entfernen der Abdeckungen die Gefahr eines elektrischen Schlags und/oder andere Gefahren bestehen.

Schlitze und Öffnungen • Wenn das Gerät Schlitze oder Löcher im Gehäuse aufweist, dienen diese zur Vermeidung einer Überhitzung der empfindlichen Teile im Inneren. Diese Öffnungen dürfen niemals von anderen Objekten blockiert werden.

Litium-Batterie • Explosionsgefahr, falls die Batterie nicht richtig ersetzt wird. Ersetzen Sie verbrauchte Batterien nur durch den gleichen oder einen vergleichbaren Batterietyp, der auch vom Hersteller empfohlen wird. Entsorgen Sie verbrauchte Batterien bitte gemäß den Herstelleranweisungen.

Advertencia

Alimentación eléctrica • Este equipo debe conectarse únicamente a la fuente/tipo de alimentación eléctrica indicada en el mismo. La alimentación eléctrica de este equipo debe provenir de un sistema de distribución general con conductor neutro a tierra. La tercera pata (puesta a tierra) es una medida de seguridad, no puentearla ni eliminarla.

Desconexión de alimentación eléctrica • Para desconectar con seguridad la acometida de alimentación eléctrica al equipo, desenchufar todos los cables de alimentación en el panel trasero del equipo, o desenchufar el módulo de alimentación (si fuera independiente), o desenchufar el cable del receptáculo de la pared.

Protección del cables de alimentación • Los cables de alimentación eléctrica se deben instalar en lugares donde no sean pisados ni apretados por objetos que se puedan apoyar sobre ellos.

Reparaciones/mantenimiento • Solicitar siempre los servicios técnicos de personal calificado. En el interior no hay partes a las que el usuario deba acceder. Para evitar riesgo de electrocución, no intentar personalmente la reparación/ mantenimiento de este equipo, ya que al abrir o extraer las tapas puede quedar expuesto a voltajes peligrosos y otros riesgos.

Ranuras y aberturas • Si el equipo posee ranuras o orificios en su caja/alojamiento, es para evitar el sobrecalentamiento de componentes internos sensibles. Estas aberturas nunca se deben obstruir con otros objetos.

Batería de litio • Existe riesgo de explosión si esta batería se coloca en la posición incorrecta. Cambiar esta batería únicamente con el mismo tipo (o su equivalente) recomendado por el fabricante. Desachar las baterías usadas siguiendo las instrucciones del fabricante.

Extron's Warranty

Extron Electronics warrants this product against defects in materials and workmanship for a period of three years from the date of purchase. In the event of malfunction during the warranty period attributable directly to faulty workmanship and/or materials, Extron Electronics will, at its option, repair or replace said products or components, to whatever extent it shall deem necessary to restore said product to proper operating condition, provided that it is returned within the warranty period, with proof of purchase and description of malfunction to:

USA, Canada, South America, and Central America:
Extron Electronics
1001 East Ball Road
Anaheim, CA 92805, USA

Asia:
Extron Electronics, Asia
135 Joo Seng Road, #04-01
PM Industrial Bldg.
Singapore 368363

Europe, Africa, and the Middle East:
Extron Electronics, Europe
Beeldschermweg 6C
3821 AH Amersfoort
The Netherlands

Japan:
Extron Electronics, Japan
Kyodo Building
16 Ichibancho
Chiyoda-ku, Tokyo 102-0082
Japan

This Limited Warranty does not apply if the fault has been caused by misuse, improper handling care, electrical or mechanical abuse, abnormal operating conditions or non-Extron authorized modification to the product.

If it has been determined that the product is defective, please call Extron and ask for an Applications Engineer at (714) 491-1500 (USA), 31.33.453.4040 (Europe), 65.6383.4400 (Asia), or 81.3.3511.7655 (Japan) to receive an RA# (Return Authorization number). This will begin the repair process as quickly as possible.

Units must be returned insured, with shipping charges prepaid. If not insured, you assume the risk of loss or damage during shipment. Returned units must include the serial number and a description of the problem, as well as the name of the person to contact in case there are any questions.

Extron Electronics makes no further warranties either expressed or implied with respect to the product and its quality, performance, merchantability, or fitness for any particular use. In no event will Extron Electronics be liable for direct, indirect, or consequential damages resulting from any defect in this product even if Extron Electronics has been advised of such damage.

Please note that laws vary from state to state and country to country, and that some provisions of this warranty may not apply to you.

安全须知 • 中文



这个符号提示用户该设备用户手册中的操作和维护说明。



这个符号警告用户该设备机壳内暴露的危险电压，有触电危险。

注意

阅读说明书 • 用户使用该设备前必须阅读并理解有安全和使用说明。

保存说明书 • 用户应保存安全说明书以备将来使用。
遵守警告 • 用户应遵守产品和用户指南上的所有安全和操作说明。

避免追加 • 不要使用该产品厂商没有推荐的工具或追加设备，以避免危险。

警告

电源 • 该设备只能使用产品上标明的电源。设备必用有地线供电系统供电。第三条线（地线）是安设施，不能不用或跳过。

拔掉电源 • 为安全地从设备拔掉电源，请拔掉所有设备后或桌面电源的电源线，或任何接到市电系统电源线。

电源线保护 • 妥善布线，避免被踩踏，或重物挤压。

维护 • 所有维修必须由认证的维修人员进行。设备部没有用户可以更换的零件。为避免出现触电危险不要自己试图打开设备盖子维修该设备。

通风孔 • 有些设备机壳上有通风槽或孔，它们是用防止机内敏感元件过热。不要用任何东西挡住通风孔。

锂电池 • 不正确的更换电池会有爆炸的危险。必须使与厂家推荐的相同或相近型号的电池。按照生产厂的议处理废弃电池。

FCC Class A Notice

This equipment has been tested and found to comply with the limits for a Class A digital device, pursuant to part 15 of the FCC Rules. Operation is subject to the following two conditions: (1) This device may not cause harmful interference and (2) this device must accept any interference received, including interference that may cause undesired operation. The Class A limits are designed to provide reasonable protection against harmful interference when the equipment is operated in a commercial environment. This equipment generates, uses, and can radiate radio frequency energy and, if not installed and used in accordance with the instruction manual, may cause harmful interference to radio communications. Operation of this equipment in a residential area is likely to cause harmful interference, in which case the user will be required to correct the interference at his own expense.

NOTE

This unit was tested with shielded cables on the peripheral devices. Shielded cables must be used with the unit to ensure compliance.

Table of Contents

Chapter 1 • Introduction	1-1
About the TP Transmitters	1-2
Features	1-3
TP T 15HD A transmitter	1-3
TP T 15HD AV transmitter	1-4
TP T 468 transmitter	1-4
TP T BNC DA4 transmitter/distribution amplifier	1-5
Chapter 2 • Installation and Operation	2-1
Installation	2-2
Overview	2-2
Video jumpers	2-3
Video DIP switch	2-5
Audio jumpers	2-5
Mounting the TP T 15HD A, TP T 15HD AV, or TP T BNC DA4	2-6
Tabletop use	2-7
UL rack mounting guidelines	2-7
Rack mounting procedure	2-7
Under-desk mounting	2-8
Through-desk mounting	2-10
Installing the TP T 468	2-11
TP T 468 installation overview	2-11
UL guidelines for wall box installation	2-12
Euro Channel models	2-12
Preparing the site and installing the mud ring or wall box	2-13
Mounting the AAP devices	2-16
Mounting the transmitter to the mud ring or wall box	2-17
Installing the Euro Channel transmitter	2-18
Grounding the transmitter	2-19
Input cabling	2-20
Computer video and PC audio	2-20
Composite video and stereo audio	2-24
RGBHV video	2-24
Transmitted signal cabling	2-25
Termination of TP cable	2-26
Cable testing	2-26
Equalizing pair skew	2-27
Power connector	2-28
Unique TP T 468 front panel features	2-29

Table of Contents, cont'd

Front Panel Control and Indicators	2-29
Troubleshooting	2-30
If the image does not appear	2-30
If the image is not displayed correctly	2-31
If the receiver's Manual/Auto LED flashes	2-31

Appendix A • Specifications, Accessories, and Part Numbers	A-1
Specifications	A-2
Included Parts	A-6
Accessories	A-7
Cables and Adapters	A-7
Optional Adapter Plates	A-8
TP T 468 Template	A-12



TP Transmitters

Chapter One

Introduction

About the TP Transmitters

Features

All trademarks mentioned in this manual are the properties of their respective owners.

68-546-03 Rev. G
07 08

About the TP Transmitters

Extron's Twisted Pair (TP) transmitters provide long-distance distribution of RGB video, component video, S-video, composite video, and stereo audio over Extron's Skew-Free™ A/V UTP cable or standard Category (CAT) 5 unshielded twisted pair (UTP), shielded twisted pair (STP), or foil shielded twisted pair (FTP) cable.

The minimum reliable transmission distance to all receivers, with the exception of the TP R 15HD A, is 50 feet (15.2 meters). There is no minimum distance for transmission to the TP R 15HD A. The maximum distance is determined by the output frequency and resolution. The following table specifies the recommended maximum transmission distances using Extron Skew-Free A/V UTP cable or UTP CAT 5 cable, terminated with CAT 6, or at least CAT 5e, rated connectors.

NOTE *Extron recommends using the highest quality cable available and affordable. We also recommend the use of pre-terminated and tested cables. Cables terminated on site should be tested before use to ensure that they comply with Category 5e specifications.*

Recommended transmission ranges at 60 Hz to TP R 15HD A

Video format	Maximum range
Composite video and audio	800' (245 m)
Component video and S-video	800' (245 m)
640 x 480	500' (150 m)
800 x 600	400' (120 m)
1024 x 768	300' (90 m)
1280 x 1024	200' (60 m)
1600 x 1200	150' (40 m)

Recommended transmission ranges at 60 Hz to all other receivers

Video format	Maximum range
Composite video and audio	1000' (300 m)
Component video and S-video	1000' (300 m)
640 x 480	1000' (300 m)
800 x 600	800' (245 m)
1024 x 768	600' (185 m)
1280 x 1024	400' (120 m)
1600 x 1200	300' (90 m)

NOTE *It is possible to exceed the recommended distances, however, image quality may be reduced.*

Each transmitted TP signal must be connected to the appropriate Extron TP receiver. This user's manual documents the installation, features, and operation of the TP transmitters only. For information about the TP receivers, refer to the *TP Receivers Family User's Manual*, which accompanies the receivers.

The TP T 468 is mountable in a 4-gang mud ring or electrical box installed in a wall or inset in furniture. It is also available in Euro Channel (EC) versions (see appendix A for part numbers). It has openings for four single space (single height) Extron Architectural Adapter Plates (AAPs).

Features

All Extron TP transmitters provide the following features:

Frequency range — Supports 15 kHz to 130 kHz horizontal frequency.

TP T 15HD A transmitter

Video input — Accepts computer analog video on a 15-pin HD female connector. With an adapter cable, the transmitter can accept Macintosh, 13W3 video, RGBHV, RGBS, RGsB, component video, S-video, or single source composite video input.

Buffered local monitor output — Allows you to view the displayed image on a local monitor that is located up to 100 feet from the transmitter, without signal reflections or crosstalk.

Audio input — Accepts PC audio on a 3.5 mm stereo mini jack.

RJ-45 connector — Provides a connection to an Extron TP RGB video receiver.

Horizontal shift — Allows you to adjust the horizontal placement of the image on the screen. Also called "horizontal centering".

Mounting — Can be rack mounted with Extron's RSM 100 TP Rack Mounting Kit (part #70-123-01) and RSU 129 1U, 9.5" deep rack shelf (part #60-190-01) or RSB 129 1U, 9.5" deep Basic Rack Shelf (part #60-604-02). It can also be furniture mounted with Extron's MBU 125 Under Desk Mounting Kit (part #70-077-01) or MBD 129 Through Desk Mounting Kit (part #70-077-02).

TP T 15HD AV transmitter

Video input

Computer video — Accepts computer analog video on a 15-pin HD female connector. With an adapter cable, the 15HD connector can accept a Macintosh video, 13W3 video, or RGBHV, RGBS, RGsB, component video, S-video, or single source composite video input.

Composite video — Accepts NTSC, PAL, and SECAM composite video on an RCA jack. Alternately, the composite video channel can support digital audio.

Buffered local monitor output — Allows you to view the displayed computer video image on a local monitor that is located up to 100 feet from the transmitter, without signal reflections or crosstalk.

Audio input — Accepts PC audio on a 3.5 mm stereo mini jack, and stereo audio on two RCA jacks.

RJ-45 connectors — One connector provides a connection to an Extron TP RGB video receiver, and the other provides a connection to a TP composite video receiver.

Horizontal shift — Allows you to adjust the horizontal placement of the computer video image on the screen.

Mounting — Can be rack mounted with Extron's RSM 100 TP Rack Mounting Kit (part #70-123-01) and RSU 129 1U, 9.5" deep rack shelf (part #60-190-01) or RSB 129 1U, 9.5" deep Basic Rack Shelf (part #60-604-02). It can also be furniture mounted with Extron's MBU 125 Under Desk Mounting Kit (part #70-077-01) or MBD 129 Through Desk Mounting Kit (part #70-077-02).

TP T 468 transmitter

Video input — Accepts computer analog video on a 15-pin HD female connector. With an adapter cable, the transmitter can accept a Macintosh, 13W3, RGBHV, RGBS, RGsB, component video, S-video, or composite video input.

Buffered local monitor output — Allows you to view the displayed image on a local monitor that is located up to 100 feet from the transmitter, without signal reflections or crosstalk.

Audio input — Accepts PC stereo audio on a 3.5 mm stereo mini jack.

RJ-45 connector — Provides a connection to an Extron TP RGB video receiver.

Horizontal shift — Allows you to adjust the horizontal placement of the computer video image on the screen.

Choice of colors — The TP T 460/468 transmitters are available with a choice of gray, black, or white front panels to match any decor.

Mounting — Wall or furniture mounted in a four-gang wall box. EC versions are available that are mountable in a Euro Channel raceway.

Adapter plate capable — Has openings for four single space (single-height) Extron AAPs with pass-through connectors.

TP T BNC DA4 transmitter/distribution amplifier

Video input — Accepts RGBHV, RGBS, RGsB, component video, and composite video on BNC connectors. With an adapter cable, the transmitter can also accept an S-video input.

RJ-45 connectors — Allows connection to up to four Extron TP RGB video receivers.

Mounting — Can be rack mounted with Extron's RSM 100 TP Rack Mounting Kit (part #70-123-01) and RSU 129 1U, 9.5" deep rack shelf (part #60-190-01) or RSB 129 1U, 9.5" deep Basic Rack Shelf (part #60-604-02). It can also be furniture mounted with Extron's MBU 125 Under Desk Mounting Kit (part #70-077-01) or MBD 129 Through Desk Mounting Kit (part #70-077-02).



Chapter Two

Installation and Operation

Installation

Front Panel Control and Indicators

Troubleshooting

Installation and Operation

Installation

CAUTION *Installation and service must be performed by authorized personnel only. The TP T 468 must be used with a UL approved electrical box.*

Overview

To install and set up a TP transmitter and the associated TP receiver(s) for operation, perform the following steps:

- 1 Disconnect power from all of the equipment, including the video source(s) (such as computers or DVD players), the transmitter, the receiver, and the output display(s).
- 2 For component, S-video, or composite video, reconfigure the jumpers (TP T 15HD A, TP T 15HD AV, and TP T BNC DA4) or DIP switch (TP T 468). See “Video jumpers” or Video DIP switch,” later in this chapter.
- 3 **TP T 15HD AV only** — If desired, configure the audio jumpers to make the transmitter compatible with unmodified TP receivers. See “Audio jumpers,” later in this chapter.

NOTE *The TP T 15HD AV is a redesigned (modified) transmitter. The audio jumpers configure the audio portion of the composite video TP link to work with the similarly redesigned TP R BNC AV receiver or with older, unmodified receivers. Redesigned transmitters and receivers have an identifying label.*

- 4 Mount the transmitter in a rack, under a desk or podium, in a desk or table (TP T 15HD A, TP T 15HD AV, or TP T BNC DA4) or in a wall (TP T 468). See “Mounting the TP T 15HD A, TP T 15HD AV, or TP T BNC DA4” or “Installing the TP T 468,” later in this chapter.
- 5 Connect the input cables. See “Input cabling,” later in this chapter.
- 6 Connect the cable(s) between the transmitter and the TP receiver(s). See “Transmitted signal cabling,” later in this chapter and refer to the *TP Receivers Family User’s Manual*.
- 7 Configure the TP receiver(s). Refer to the *TP Receivers Family User’s Manual*.

- 8 Connect power cords to the TP receiver, the TP transmitter, and turn on the video source(s) and the output display(s).

NOTE *All TP transmitters include a 15 V external power supply. The transmitters also receive power from the associated Extron TP receiver(s) (with the exception of the TP R 15HD A) via the TP cable. Extron recommends using the local power supply; however, the power supply may not be necessary in some applications.*

- *The TP T 15HD A, TP T 15HD AV, TP T 468, and TP T BNC may not require a local power supply for cable lengths of 300’ (91 m) or less.*
- *The TP T BNC DA4 and any transmitter connected to a TP R 15HD A always require the local power supply.*

If you encounter problems, use the local power supply.

- 9 Adjust the picture controls on the front panel of the transmitter and receiver(s). See “Front Panel Control and Indicator,” later in this chapter, and refer to the *TP Receivers Family User’s Manual*.
- 10 **TP T 468 only** — Mount the transmitter into the mud ring or electrical box. See “Mounting the AAP devices” and “Mounting the transmitter to the mud ring or wall box” or “Euro Channel transmitter installation,” later in this chapter.
- 11 **TP T 468 only** — Restore power to the devices.

Video jumpers

The TP T 15HD A, TP T 15HD AV, TP T BNC, and TP T BNC DA4 transmitters can be configured to transmit component video, S-video, or composite video.

NOTE *The transmitters are factory configured for RGB video. For any other type of video, reconfigure the jumpers.*

1. Remove the two screws on each side and the screw on top of the cover (figure 2-1).

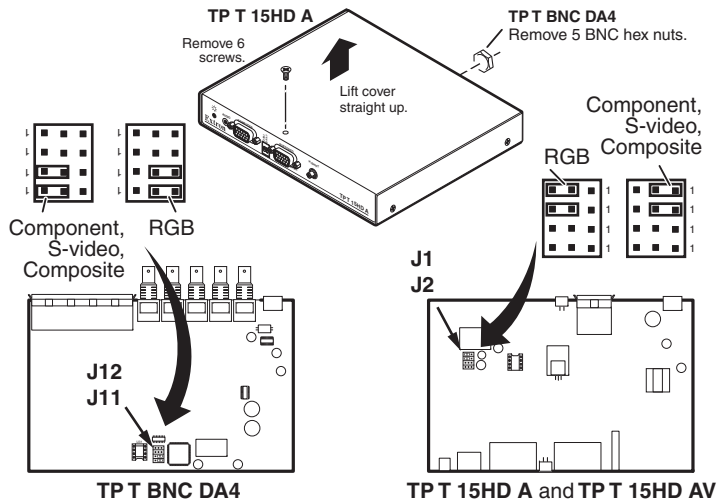

Figure 2-1 — Video jumper configuration

2. **TP T BNC DA4:** Using an Extron BNC extraction tool (part #100-096-01) or a 14 mm, deep well socket with thin walls, remove the five hex nuts securing the BNC connectors to the rear panel. Slide the cover forward until the cover clears the BNC connectors
3. Lift the cover off.
4. **TP T 15HD A and TP T 15HD AV:** Locate J1 and J2 on the printed circuit board. See figure 2-1.
 - a. **For RGB video**, ensure that pin 2 is jumpered to pin 3 on both jumper locations.
 - b. **For any other video format**, ensure that pin 1 is jumpered to pin 2 on both jumper locations.

TP T BNC DA4: Locate J11 and J12 on the printed circuit board. See figure 2-1.

- a. **For RGB video**, ensure that pin 2 is jumpered to pin 3 on both jumper locations.
 - b. **For any other video format**, ensure that pin 1 is jumpered to pin 2 on both jumper locations.
5. Replace the cover and reinstall the screws.

Video DIP switch

The TP T 468 can be configured to transmit component video, S-video, or composite video. To configure the TP T 468 for RGB video, set DIP switch 2 on the back of the transmitter to Off. For any other video format set the switch to On.



Audio jumpers

NOTE Older (unmodified) transmitters and receivers are fully compatible with each other **but not** with the TPX 88 A twisted pair matrix switcher.

Redesigned (modified) transmitters and receivers are fully compatible with each other **and with** the TPX 88 A. They can also be jumpered to be compatible with the older (unmodified) receivers and transmitters **but not** the TPX 88 A.

NOTE Redesigned (modified) transmitters and receivers have an identifying label.

The audio that is associated with the composite video link of TP T 15HD AV transmitters is transmitted on wire pair 3 and 6. This configuration is compatible with redesigned TP receivers and the TPX 88 A.

If you intend to match this transmitter with an older, unmodified TP receiver, and do not plan to include a TPX 88 A in your system, you can set the transmitter to send the audio on wire pair 7 and 8, to be compatible with an older TP receiver, by shifting internal jumpers as follows:

1. Remove the two screws on each side and the screw on top of the cover (figure 2-2).

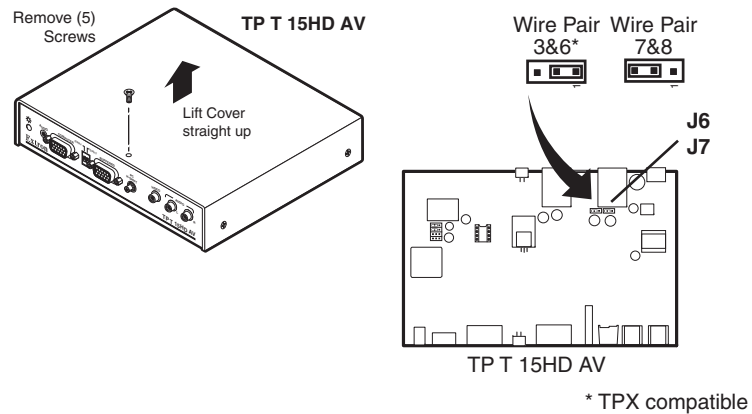

Figure 2-2 — Audio jumper configuration

2. Lift the cover off.
3. Locate J6 and J7 on the printed circuit board. See figure 2-2.
 - a. **For compatibility with redesigned (modified) receivers and the TPX 88 A**, ensure that pin 1 is jumpered to pin 2 on both jumper locations.
 - b. **For compatibility with older (unmodified) receivers**, ensure that pin 2 is jumpered to pin 3 on both jumper locations.
4. Replace the cover and reinstall the screws.

Mounting the TP T 15HD A, TP T 15HD AV, or TP T BNC DA4

The TP T 15HD A, TP T 15HD AV, and TP T BNC DA4 transmitters can be set on a table; mounted on a rack shelf; or mounted through or under a desk, podium, or tabletop. The following optional mounting kits are available for the series:

- RSM 100 TP rack mounting kit (#60-604-02)
- RSB 129 1U, 9.5" deep basic rack shelf (#60-604-02)
- RSU 129 1U, 9.5" deep rack shelf kit (#60-190-01)
- MBU 125 under-desk mounting bracket kit (#70-077-01)
- MBD 129 through-desk mounting bracket kit (#70-077-02)

Tabletop use

Four self-adhesive rubber feet are included with the unit. For tabletop use, affix one foot at each corner of the bottom of the transmitter, and place the unit in the desired location.

UL rack mounting guidelines

The following Underwriters Laboratories (UL) guidelines pertain to the safe installation of the equipment in a rack.

1. **Elevated operating ambient temperature** — If the equipment is installed in a closed or multi-unit rack assembly, the operating ambient temperature of the rack environment may be greater than room ambient temperature. Therefore, install the equipment in an environment compatible with the maximum ambient temperature ($T_{ma} = +113\text{ }^{\circ}\text{F}$, $+45\text{ }^{\circ}\text{C}$) specified by Extron.
2. **Reduced air flow** — Install the equipment in a rack so that the amount of air flow required for safe operation of the equipment is not compromised.
3. **Mechanical loading** — Mount the equipment in the rack so that a hazardous condition is not achieved due to uneven mechanical loading.
4. **Circuit overloading** — Connect the equipment to the supply circuit and consider the effect that circuit overloading might have on overcurrent protection and supply wiring. Also consider equipment nameplate ratings when addressing this concern.
5. **Reliable earthing (grounding)** — Maintain reliable grounding of rack-mounted equipment. Pay particular attention to supply connections other than direct connections to the branch circuit (e.g., use of power strips).

Rack mounting procedure

To mount the transmitter on a 9.5" deep rack shelf,

1. If rubber feet were previously attached to the bottom of the unit, remove them.
2. Fit the RSM 100 mounting bracket around the transmitter and attach it to the unit using one mounting hole on each end.
3. Mount the bracket containing the unit onto the rack shelf, using two 4-40 x 3/16" screws in the two mounting holes in the bottom of the bracket to secure it.
4. Install blank panel(s) or other unit(s) on the rack shelf as desired.

5. Attach the rack shelf to the rack using the supplied bolts.

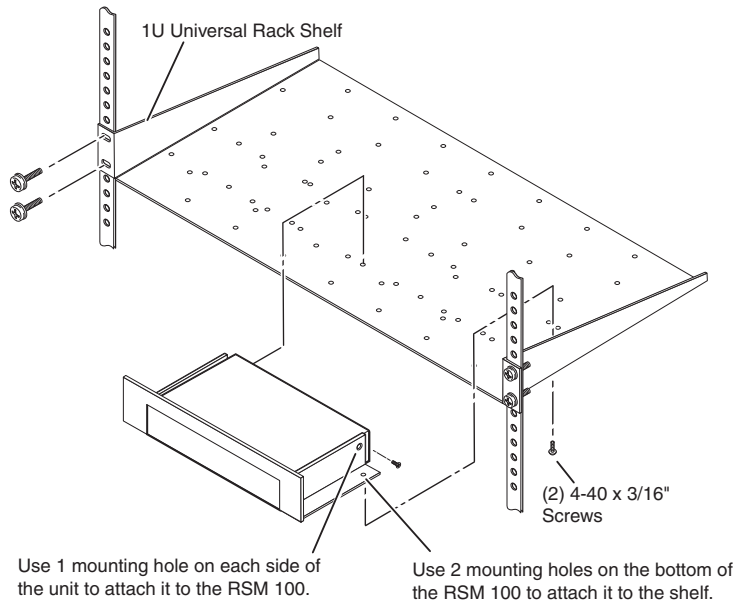

Figure 2-3 — Rack mounting a TP T series transmitter

Under-desk mounting

Furniture-mount the transmitter under a desk or shelf using the optional mounting kit (part #70-077-01), as illustrated below.

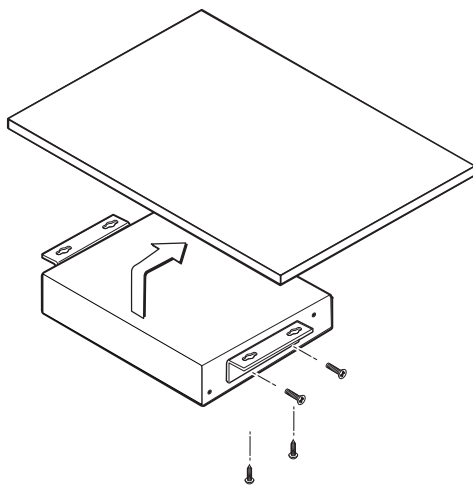

Figure 2-4 — Under-desk mounting the transmitter

To mount the transmitter under a desk, podium, or table top,

1. If rubber feet were previously attached to the bottom of the unit, remove them.
2. Remove the two screws from one side of the unit. Retain the screws for possible later reassembly.
3. Attach one bracket to the side of the unit, using the provided machine screws.
4. Repeat steps 2 and 3 on the other side of the unit.
5. Hold the unit with the attached brackets against the underside of the table or other furniture. On the mounting surface, mark the location of the bracket's screw holes.
6. Drill pilot holes 1/4" (6.4 mm) deep and 3/32" (2 mm) in diameter into the table or desk top at the marked screw locations. The holes should be drilled from the underside or inside (concealed side) of the furniture where the transmitter will be located.
7. Insert #8 wood screws into the four pilot holes. Tighten each screw into the mounting surface until slightly less than 1/4" of the screw head protrudes.
8. Align the mounting screws with the slots in the brackets and place the unit against the surface, with the screws through the bracket slots.
9. Slide the unit slightly forward or back, then tighten all four screws to secure it in place.

Through-desk mounting

Mount the transmitter through a desk or table, using the optional through-desk mounting kit (part #70-077-02).

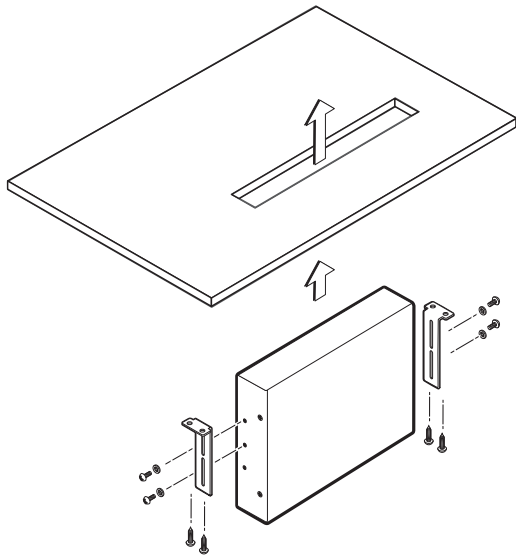

Figure 2-5 — Through-desk mounting the transmitter

1. Mark the opening through which the unit will be mounted — approximately 1.2" by 6.9" (3.0 cm by 17.5 cm).
2. Cut out the material from the installation area with a jigsaw.
3. Drill pilot holes 1/4" (6.4 mm) deep and 3/32" (2 mm) in diameter in the desk or table at the locations of the mounting bracket screws. The holes should be drilled from the underside or inside (concealed side) of the furniture where the transmitter will be located.
4. Using the four provided wood screws, attach the brackets to the mounting surface.
5. Slide the unit up and down or back and forth in the mounting brackets until the front panel of the unit is at the desired height. Tighten the screws that secure the bracket in place.

If the screws are inaccessible to a screwdriver,

- a. Mark the location of the brackets relative to the screws.
- b. Remove the transmitter from inside the furniture.

- c. Tighten the screws.
- d. Replace the unit inside the surface (repeat step 4).

Installing the TP T 468

TP T 468 Installation Overview

To install a TP T 468 transmitter, follow these steps:

1. Disconnect power from all of the equipment, including the video source(s) (such as computers or DVD players), the transmitter, the receiver, and the output display(s).
2. **For non-Euro Channel (EC) versions**, prepare the site: cut a hole in the wall/furniture, install the electrical box or mud ring, and prepare the cables. Instructions are included in this manual and/or with the wall box. See "Preparing the site and installing the mud ring or wall box," later in this chapter.

For the EC versions, see "Euro Channel transmitter installation," later in this chapter.
3. Connect the input cables. See "Input cabling," later in this chapter.
4. Connect the cable(s) between the transmitter(s) and the TP receiver(s). See "Transmitted signal cabling," later in this chapter, and refer to the *TP Receivers Family User's Manual*, part #68-547-01.
5. Configure the TP receiver(s). Refer to the *TP Receivers Family User's Manual*, part #68-547-01.
6. Connect power cords to the TP receiver(s), the TP transmitter(s) (if applicable), and turn on the video source(s) and the output display(s).

NOTE *The TP T 468 includes a 15 VDC external power supply. The transmitter also receives power from the associated Extron TP receiver via the TP cable. Extron recommends using the local power supply; however, the TP T 468 may not require a local power supply for cable lengths of 300' (91.4 m) or less. If problems are encountered, use the local power supply.*

7. Adjust the picture controls on the front panel of the transmitter and receiver. See Front Panel Control and Indicators, later in this chapter, and refer to the *TP Receivers Family User's Manual*, part #68-547-01.
8. Disconnect power from all the devices.

Installation and Operation, cont'd

- 9 Install the desired AAPs on the transmitter. See "Mounting the optional AAP devices," later in this chapter.
- 10 Mount the transmitter into the electrical box or to the mud ring. If using a wall box, see "Mounting the transmitter to the mud ring or wall box," later in this chapter.
- 11 Restore power to the devices.

UL guidelines for wall box installation

The following Underwriters Laboratories (UL) requirements pertain to the installation of the TP T 468 into a wall or furniture (figure 2-6).

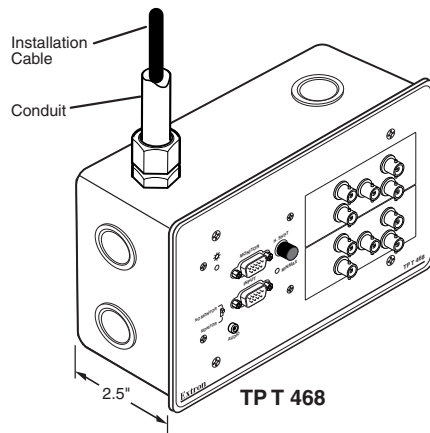

Figure 2-6 — TP T 468 in a four-gang wall box

1. This unit is not to be connected to a centralized DC power source or used beyond their rated voltage range.
2. This unit must be installed in UL listed junction boxes.
3. This unit must be installed with conduit in accordance with the National Electrical Code.

Euro Channel models

The TP T 468 is available in a Euro Channel (EC) version (see appendix A for part numbers).

The front and rear panel features, cabling requirements, and testing/troubleshooting procedures are identical to the descriptions shown in chapter 2, *Installation and Operation*, for the non-EC models. See *Euro Channel transmitter installation* in this appendix for the EC transmitter model installation instructions.

Preparing the site and installing the mud ring or wall box

The TP T 468 is mounted into a wall or furniture. Follow the instructions appropriate to the mounting option you have selected. Templates for optional faceplates are not included in this manual.

CAUTION *The transmitter must be installed into an Underwriters Laboratories (UL) approved electrical wall box.*

Choose a location that allows cable runs without interference. Allow enough depth for both the wall box and the cables. You may need to install the cables into the wall, furniture, or conduits before installing the transmitter.

The installation must conform to national and local electrical codes and to the equipment's size requirements. An actual-size cut-out template is provided in appendix A of this manual.

Installation using a UL listed wall box (available from Extron) is recommended for most mounting options, but the included mud rings can be used instead. All wall boxes must be at least 2.5" (6.4 cm) deep.

NOTE *Before using the mud rings, verify that the installation conforms to national and local electrical codes.*

1. Select and cut out the appropriate template for your installation type:
 - **If you are using a mud ring**, use the template provided with the mud ring. Cut out the indicated center portion.
 - **If you are using a wall box**, cut out or make a 100% size photocopy of the template in appendix A that corresponds to the faceplate you are using, and cut out the center portion as indicated on the template.
2. Place the template (or the wall box or mud ring) against the installation surface, and mark the guidelines for the opening on the wall or furniture.
3. Cut out the wall or furniture material from the marked area.
4. Check the opening size by inserting the wall box, mud ring, or transmitter into the opening. The box or mud ring (if used) and/or transmitter should fit easily into the opening. Enlarge or smooth the edges of the opening if needed.

Installation and Operation, cont'd

5. If you are using a wall box, feed cables through the wall box punch-out holes, and secure them with cable clamps to provide strain relief.
6. Exposed cable shields (braids or foil) are potential sources of short circuits. Trim back and/or insulate shields with heat shrink (figure 2-7).

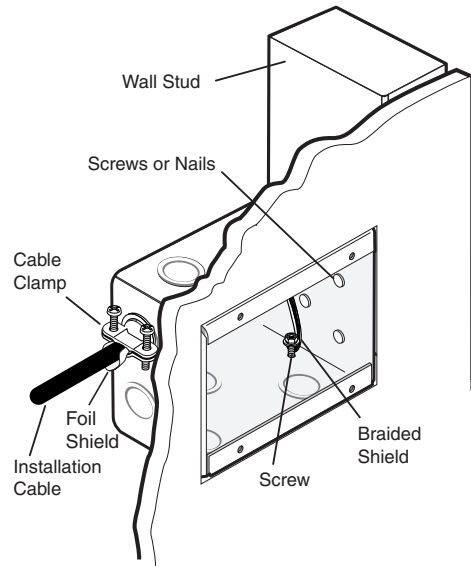

Figure 2-7 — Grounding outer braided and foil shields

WARNING

To prevent short circuits, cut back the outer foil shield to the point where the cable exits the cable clamp. Both braided and foil shields should be connected to an equipment ground at the other end of the cable.

7. If you are using a mud ring, follow the directions, if any, that came with the mud ring to attach the clips that fasten it to the wall or furniture (figure 2-8).

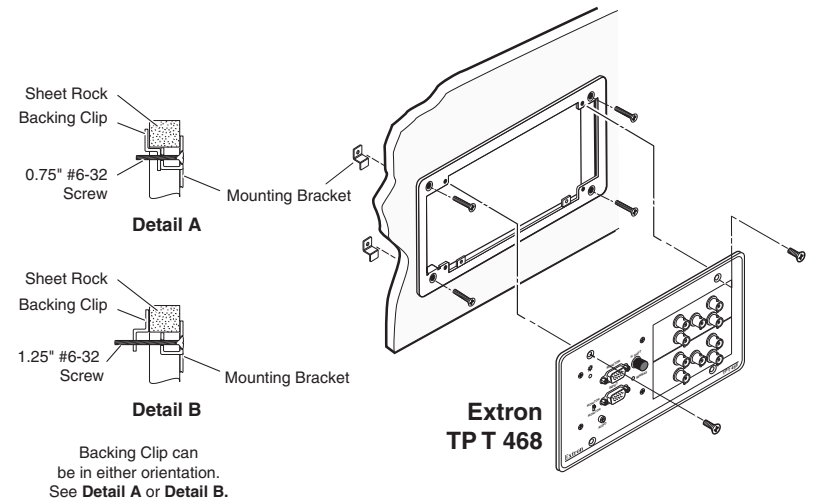

Figure 2-8 — Attaching a mud ring to a wall

If you are using a wall box, insert the wall box into the opening, and attach it to the wall stud/furniture with nails or screws, leaving the front edge flush with the outer wall or furniture surface (figure 2-9).

If attaching the wall box to wood, use four #8 or #10 screws or 10-penny nails. A minimum of 1/2 inch (1.3 cm) of screw threads must penetrate the wood.

If attaching the wall box to metal studs or furniture, use four #8 or #10 self-tapping sheet metal screws or machine bolts with matching nuts.

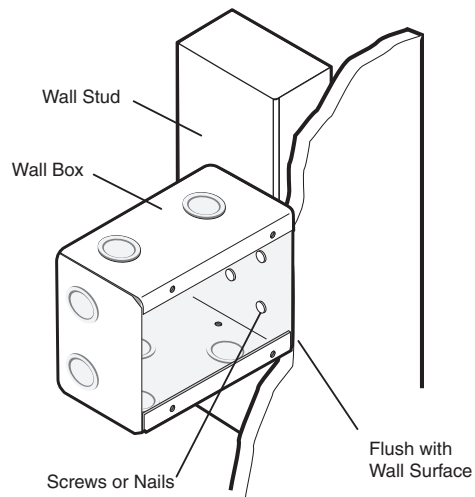

Figure 2-9 — Attaching a wall box to a wall stud

8. Cable and install the desired AAPs, set the Composite/RGB and DDSP DIP switches, and cable and test the transmitter before fastening the transmitter into the wall box. See Input cabling, later in this chapter, for details.

NOTE *The AAPs, switches, and cable are inaccessible after installation.*

Mounting the AAP devices

The TP T 468 faceplates accept up to four optional single height Extron Architectural Adapter Plates (AAPs). The adapter plates allow for a variety of connectors.

Blank plates (two single-space and one double-space plate) are included on the transmitter to cover unused spaces. Adapter plates must be ordered separately. They also must be attached to the faceplate and cabled before the interface is installed in the wall or furniture (figure 2-10). The screws needed for installing the adapter plates are built into the plates, so no additional screws are needed.

1. Remove the blank plates from the interface by unscrewing the nuts that fasten the plates to the faceplate.
2. Insert the adapter plate screws through the holes in the faceplate. Attach the adapter plates to the faceplate with the provided captive washers and #4-40 nuts.

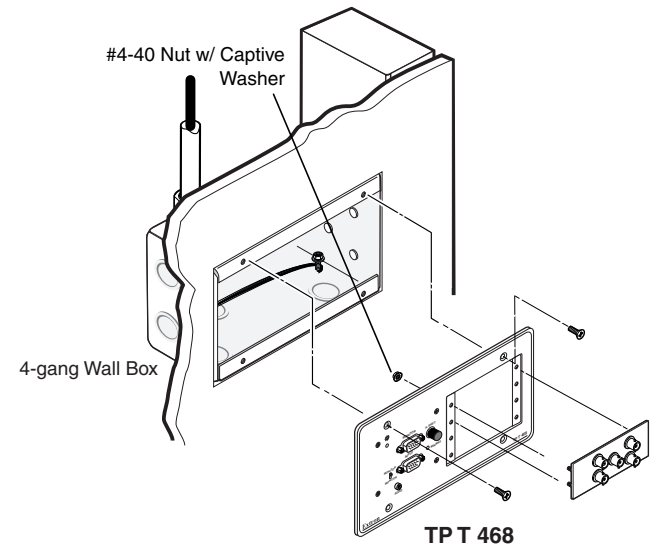

Figure 2-10 — Mounting an AAP

3. Attach the output cables to the rear connectors of the adapter plates. Soldering will be required for some connectors. Attach foil and braided shields to ground connections.

Mounting the transmitter to the mud ring or wall box

1. Remove power from the interface by disconnecting the power supply.
2. Place the interface through the opening in the wall or furniture and into the wall box. Take care not to damage the cables, which fit behind the interface, at the back of the wall box.
3. Mount the interface's faceplate to the mud ring or wall box with machine screws (figure 2-11 on the next page).

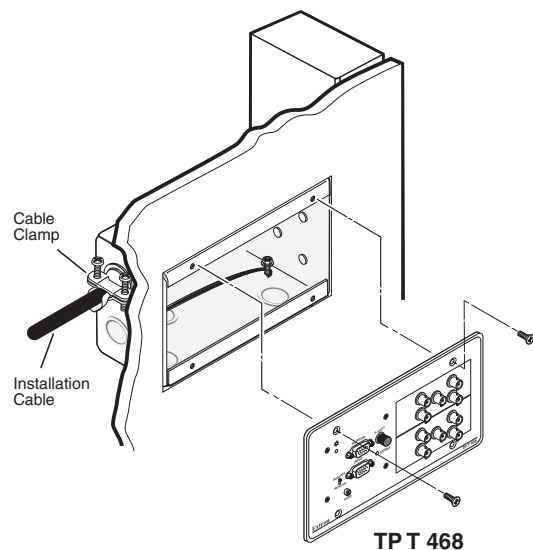

Figure 2-11 — Mounting the transmitter to the wall box

4. Reconnect the power supply and restore power to the equipment.

Installing the Euro Channel transmitter

Once the EC transmitter has been cabled and tested, the transmitter can be installed in the Euro Channel.

1. Remove power from the interface by disconnecting the power supply.
2. Mount the interface to the Euro Channel by attaching the faceplate to the two mounting brackets using the four #4-40 mounting screws (figure 2-12).

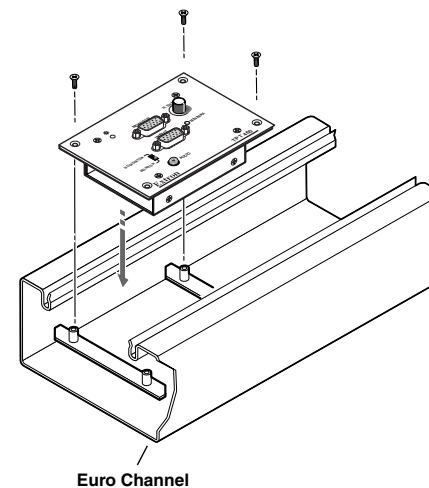

Figure 2-12 — Mounting the transmitter in a Euro Channel

Grounding the transmitter

RGB and computer video transmitters may need to be grounded to ensure that the video and audio are not degraded. The TP T 15HD A, TP T 15HD AV, and TP T 468 may require grounding if all of the following conditions are true:

- The signal source is a laptop computer.
- No local monitor is connected.
- A local power supply is not being used.

Grounding may also be required if there is no common ground in the power distribution system.

Indications that grounding may be required include:

- The receiver's Power LED is lit amber when a connection is made to the transmitter.
- The receiver is in auto mode and its Manual/Auto LED flashes.
- The receiver is in manual mode and an image appears only when the Peaking adjustment is at the minimum level. Additionally, the image may be overpeaked with horizontal streaking to the right of displayed information.
- No audio, or distorted and noisy audio, is heard.

Ground the transmitter using any of the following methods:

- Connect a local 15 V power supply to the transmitter.
- Use STP rather than UTP cable and connectors.
- **TP T 15 HD A and TP T 15HD AV** — Use a 3.5 mm captive screw connector to connect a ground wire between the power return pin (figure 2-13) and a grounding point near the transmitter, such as a grounded power outlet or an equipment rack.
- **TP T 468 only** — Connect a ground wire between the power return pin (figure 2-13) of the 3.5 mm, 2-pole direct-insertion captive screw connector on the rear of the transmitter and a grounding point near the transmitter.

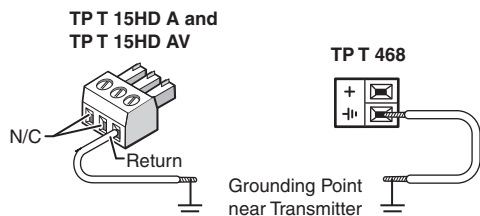

Figure 2-13 — Grounding the transmitter

Input cabling

Computer video and PC audio

The TP T 15HD A (figure 2-14), the TP T 15HD AV (figure 2-15), and the TP T 468 (figure 2-16) all accept and transmit computer video and PC audio. These transmitters can also accommodate component video, S-video, or composite video if input on the R, G, and B pins of the 15HD connector using an Extron SYM BNCF/0.5 6" (15 cm) cable, part #26-531-01.

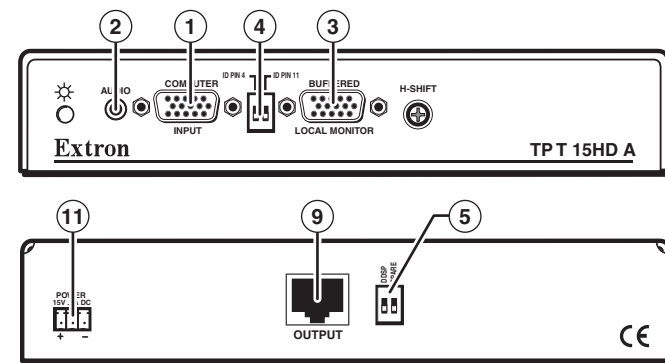

Figure 2-14 — Installation features, TP T 15HD A

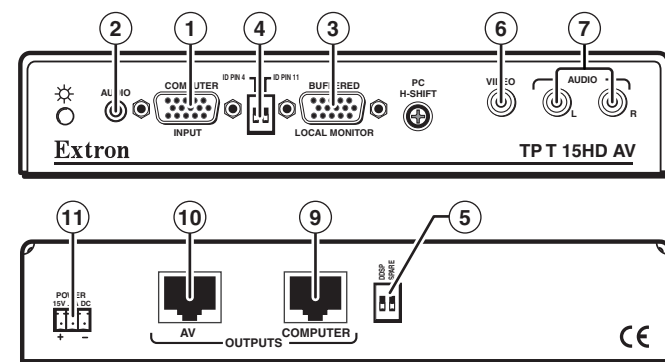

Figure 2-15 — Installation features, TP T 15HD AV

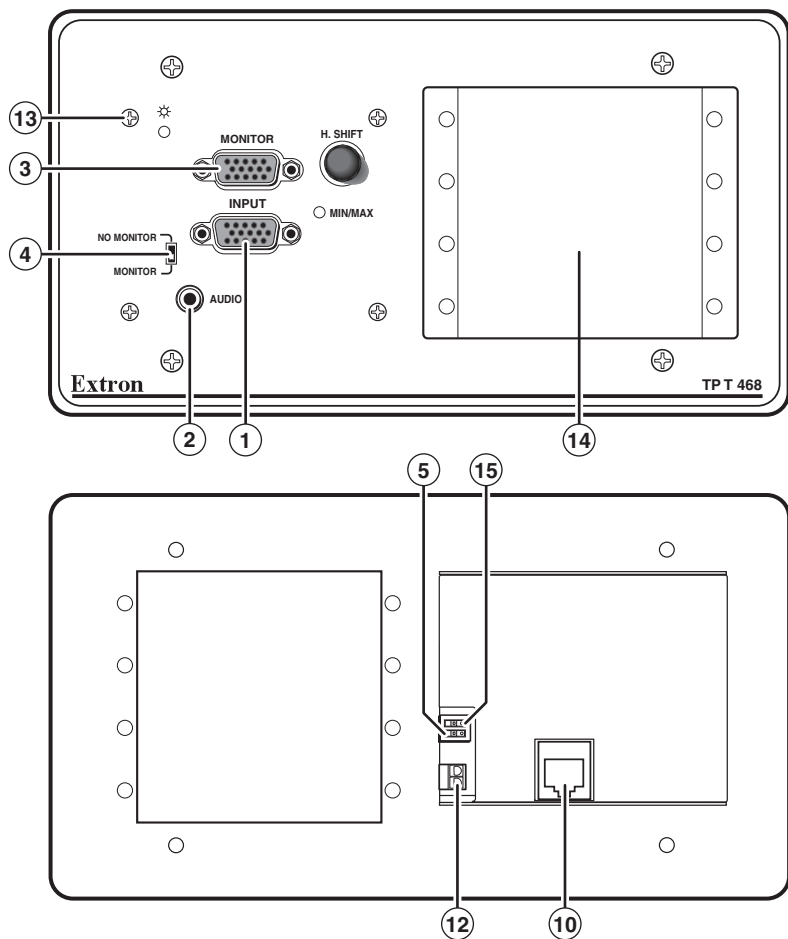
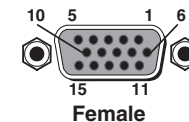

Figure 2-16 — Installation features, TP T 468

Transmission of component video, S-video, or composite video on the computer video input requires that internal jumpers (TP T 15HD A and TP T 15HD AV) or a DIP switch (TP T 468) be reconfigured. See “Video jumpers,” or “Video DIP switch,” earlier in this chapter.

- 1 **Computer Input connector** — Connect a computer video source to this 15-pin HD female connector.



NOTE *Input only sync signals, no video signals, on the sync pins (pins 13 and 14).*

For component video, use the R (R-Y) and R return pins (pins 1 and 6), G (Y) and G return pins (pins 2 and 7), and B (B-Y) and B return pins (pins 3 and 8).

For S-video, use the R, R return (C-chroma), G, and G return (Y-luma) pins.

For composite video, use the G pin and the associated return pin. For additional genlocked video signals, use the R, B, and associated return pins.

- 2 **Audio input connector** — Connect PC audio to this 3.5 mm, stereo jack. Wire the male plug as shown in figure 2-17.

NOTE *Input only analog, line level, audio signals on the audio input connector.*

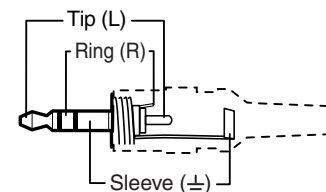

Figure 2-17 — Audio input wiring

- 3 **Buffered Local Monitor output connector** — Connect a local monitor video cable to this 15-pin HD female connector.
- 4 **ID bit switches (TP T 15HD A and TP T 15HD AV)** — If a local monitor is installed, set both switches to off. If no local monitor is installed, set both switches to on.
- 5 **DDSP switch** — This switch turns on Digital Display Sync Processing, disabling sync processing for LCD projectors and other displays that cannot tolerate processed sync.

NOTE *DDSP disables the horizontal shift control.*

Installation and Operation, cont'd

Composite video and stereo audio

The TP T 15HD AV (figure 2-15) accepts and transmits composite video and stereo audio.

- ⑥ **RGB/video switch (TP T 468 only)** — Configures the transmitter for RGB or component/S-video/composite video. See “Video DIP switch,” earlier in this chapter.
- ⑦ **Video connector** — Connect composite video to this RCA connector. Digital audio can also be connected to this connector.
- ⑧ **Audio input connectors** — Connect left and right stereo audio to these RCA connectors.

NOTE *Input only analog, line level audio signals on these connectors.*

RGBHV video

The TP T BNC DA4 (figure 2-18) accepts and transmits RGBHV, RGBS, RGsB, component video, S-video, and composite video.

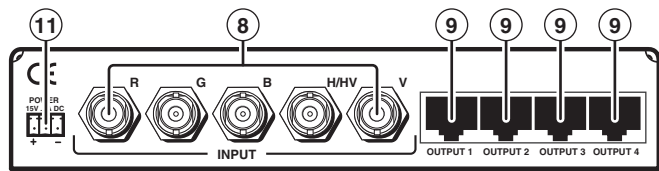

Figure 2-18 — Installation features, TP T BNC DA4

- ⑨ **Video connector** — Connect the desired video input device to the rear panel input BNCs. Transmission of component video, S-video, or composite video requires that internal jumpers be reconfigured. See “Video jumpers,” earlier in this chapter.

NOTE *Input only sync signals (no video signals) on the H/V and V BNCs.*

For RGBHV video, use the R, G, B, H/HV, and V BNCs.



For RGBS video, use the R, G, B, and H/HV BNCs.



For component video, use the R (R-Y), G (Y), and B (B-Y) BNCs.



For S-video, use the R (C-chroma) and G (Y-luma) BNCs.



For composite video, use the G BNC. For three separate genlocked video signals, use the R, G, and B BNCs.



NOTE *The TP T 15HD AV is backwards compatible with the TP T 15HD A and the TP T BNC DA4.*

However, the TP T 15HD A and the TP T BNC DA4 (products whose part numbers end in -02) are not forward compatible with the TP T 15HD AV (whose part number ends in -03).

Transmitted signal cabling

CAUTION *Do not connect this device to a computer data or telecommunications network*

NOTE *RJ-45 termination must comply with the TIA/EIA T 568A wiring standards for all connections.*

- ⑩ **RGB video transmission connector** — Attach one end of a TP cable to this RJ-45 female connector. Attach the other end to an Extron TP BNC receiver.
- ⑪ **Composite video transmission connector** — Attach one end of a TP cable to this RJ-45 female connector. Attach the other end to an Extron TP composite video receiver.

Termination of TP cable

Figure 2-19 details the recommended termination of TP cables in accordance with the TIA/EIA T 568A wiring standards.

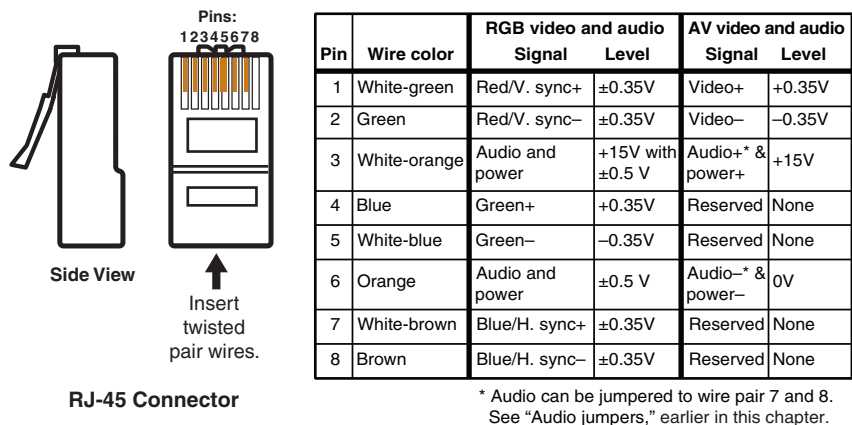

Figure 2-19 — TP cable termination

Cable testing

To ensure proper cable termination, each transmission cable system that uses CAT 5e or CAT 6 cable should be tested (Extron's Skew-Free UTP cable does not need to be tested). Testing the cable from the RJ-45 connections at the transmitter and receiver gives the most accurate indications of cable problems.

There are two varieties of cable runs: simple runs, in which a single cable is terminated only at the transmitter and receiver, and complex runs, which can include patch bays and multiple terminations and lengths of cable. In either case, the entire cabling system should be tested.

A complete test measures cable length and tests the wire map, attenuation, NEXT, PSNEXT, ELFEXT, PSELFEXT, return loss, ACR and PSACR. All of these tests are critical for digital data transfer. While all of these tests are important indicators of the quality of the cable termination, the most critical testing parameters for video transfer are wire map (T-568-A termination) and pair length measurements. The largest concern is equalization of skew between cable pairs. Cable systems of 300' (91.4 m) or less should exhibit no transmission problems if they pass at least CAT 5e or preferably CAT 6-D5 channel certification testing.

The Microtest OMNI SCANNER 2 performs comprehensive certification testing to the CAT 6 standards. Other manufacturers also make testing equipment. The tests include advanced diagnostics for troubleshooting the cause and location of many cable and termination problems. For simple installation testing, the Microtest MICRO SCANNER PRO tests wire map and cable length, including individual cable pair length.

Equalizing pair skew

The manufacturing process for network (CAT 5e) UTP cable leads to a condition called pair skew. For best results, pair skew needs to be equalized when using the CAT 5e cable in A/V applications. The design of Extron's Skew-Free A/V UTP cable minimizes pair skew to the point that equalization is not required.

Skew exists between pairs when the physical length of one wire pair is different from another. As the transmission cable length increases, the amount of skew increases. Skew affects the displayed image when the differential length between wire pairs exceeds 2' (61 cm), causing the timing of the red, green, and blue video signals to appear out of alignment (horizontal registration errors). A white vertical line on a black field can appear as individual red, green, and blue lines that are close together; the signal transmitted on the shortest wire pair leads the other colors and appears to the left on the display.

UTP cable test equipment measures and reports wire pair length. The report on the various pair lengths can be used in equalizing pair skew. The nominal velocity of propagation (NVP — the speed at which the signal travels on the transmission line, measured as a percentage of the speed of light) of TP cable is very close to that of conventional coaxial cable. The similarity in NVP means that an additional length of coax equal to the length of pair skew, placed on the receiver's output, equalizes the effects of pair skew (figure 2-20).

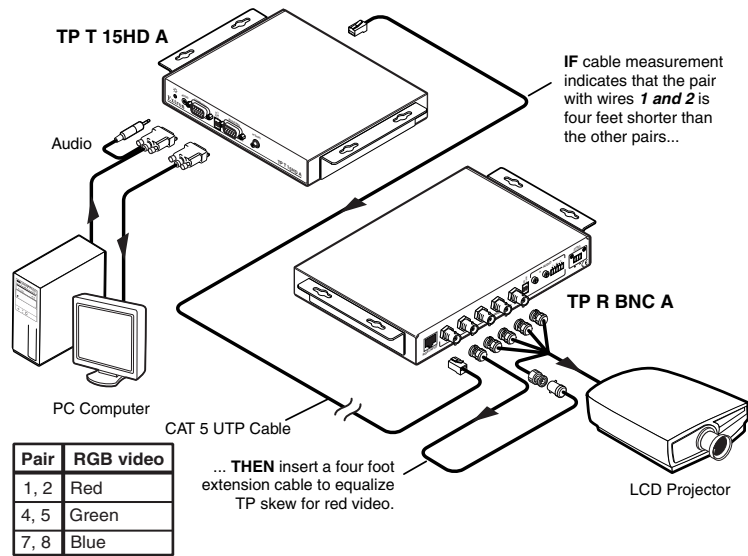

Figure 2-20 — Pair skew equalization

If UTP cable test measurement cannot be done, pair skew can still be equalized by viewing a test pattern with a critical eye. Examine the test pattern for loss of horizontal registration and, through a process of trial and error, equalize any pair skew with coax extensions on the red, green, and/or blue outputs.

Extron skew compensation coax cables are available in lengths of 2 through 20 feet (61 cm through 6.1 meters). See appendix A for part numbers.

Power connector

12 Power

TP T BNC DA4 — Plug the external 15V power supply into this captive screw connector.

NOTE *If the distance between the transmitter and receiver is too great for the receiver to power the transmitter, the video image will be missing, distorted, or noisy, or the receiver's Manual/Auto LED will flash. The transmitter requires a local 15V power supply.*

TP T 15HD A and TP T 15 HD AV — If desired or for distances over 300' (91.4 m), plug an external 15 VDC power supply into this captive screw connector. Wire the connector as shown at left.

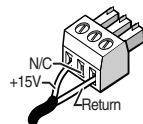

Unique TP T 468 front panel features

- 13 **Faceplate screws** — These screws secure the faceplate to the rest of the transmitter.

NOTE *Do not remove these faceplate screws while the transmitter is attached to the wall or the detached transmitter circuit board may fall down inside the wall.*

- 14 **Opening for Architectural Adapter Plates** — The TP T 468 can have up to four optional adapter plates attached here at one time. The adapter plates allow for a variety of connectors.

Blank plates (two single-space and one double-space plate) are included on the transmitter to cover unused spaces. Adapter plates must be ordered separately. They also must be attached to the faceplate and cabled before the interface is installed in the wall or furniture. See "Mounting the AAP devices," earlier in this chapter.

Front Panel Control and Indicators

All of the transmitters have front panel Power indicators. In addition, the TP T 15HD A and TP T 15HD AV have horizontal shift control.

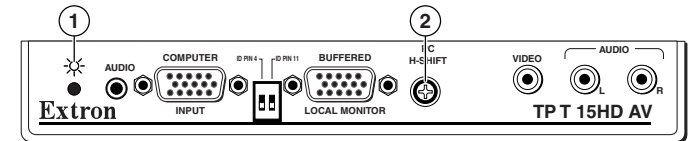

Figure 2-21 — TP T 15HD AV control and indicator

1 Power/signal LED

Amber — Indicates that power is applied, but that the transmitter is not connected to a receiver.

Green — Indicates that the transmitter is properly connected to a receiver.

2 H. Shift control (TP T 15HD A and TP T 15HD AV) — This front panel knob adjusts the side-to-side image placement.

The H. Shift control is a 12-turn potentiometer with a soft mechanical stop at the high or low end. When you have reached the high or low end of the adjustment, the potentiometer makes a clicking sound as you turn it, and no change is apparent on the display.

- ③ **Min/Max LED (TP T 468 only)** — This front panel LED blinks red momentarily whenever the minimum or maximum limits of the horizontal shift control (②) have been reached. Continually turning the horizontal shift control knob in the same direction after the limit has been reached will cause the LED to continually blink.

NOTE For details on the ID bit (TP T 15HD A and TP T 15HD AV) or Monitor/No Monitor (TP T 468) and DDSP switches, see “Computer video and PC audio,” earlier in this chapter.

Troubleshooting

If the image does not appear

1. Ensure that all devices are receiving power. The transmitter’s and receiver’s front panel Power LEDs indicate that they are receiving power.
2. Ensure that the transmitter is receiving a video input.
3. Ensure that the TP cable(s) are properly terminated in accordance with TIA/EIA T 568A standards and that the RJ-45 connections are securely made. If the Power LEDs on the transmitter and the receiver are lit green, a transmitter is properly connected to a receiver.
4. For computer/RGB video, ensure that the receiver’s SOG and C Sync switches are in the correct positions for the video output.
5. For computer video, ensure that the transmitter’s ID bit switches are on.
6. For computer video on an LCD projector, ensure that the transmitter’s DDSP switch is on.
7. The transmission distance may be too far for remote power. Try connecting the local 15 VDC power supply to the transmitter.
8. The transmission distance may be too short. Ensure that the UTP cable is at least 50' (15.2 m) long.
9. If the Manual/Auto switch is in the manual position, ensure that the receiver’s level controls are not set too high. Too much level and peaking can cause display problems.

10. For computer video from a laptop or for ungrounded AC distribution systems, the transmitter may need to be grounded. See “Grounding the transmitter,” earlier in this chapter.
11. Call the Extron S³ Sales & Technical Support Hotline if necessary.

If the image is not displayed correctly

1. For computer/RGB video, if the output image looks too green, ensure that the receiver’s SOG switch is off.
2. For computer video, if the picture hangs off the edge of the screen, adjust the transmitter’s H Shift control.

NOTE DDSP disables the horizontal shift control.

3. Place the receiver’s Manual/Auto switch to manual and adjust the level and peaking controls for optimum quality.
4. The transmission distance may be too far for remote power. Try connecting the local 15VDC power supply to the transmitter.
5. For computer video from a laptop or for ungrounded AC distribution systems, the transmitter may need to be grounded. See “Grounding the transmitter,” earlier in this chapter.
6. If the image still does not display properly, call the Extron S³ Sales & Technical Support Hotline. (See the rear cover of this manual for the phone number for your region of the world.)

If the receiver’s Manual/Auto LED flashes

1. The transmission distance may be too far for remote power. Connect the local 15VDC power supply to the transmitter.
2. Check the RJ-45 connector for a loose connection.



A

Appendix

Specifications, Accessories, and Part Numbers

Specifications

Included Parts

Accessories

Cables/Adapters

Specifications, Accessories, and Part Numbers

Video

Number/signal type	1, 2, or 4 sets of proprietary analog signals
Connectors	1, 2, or 4 shielded RJ-45 female

Video input

Number/signal type	
TP T 15HD A, TP T 468 ...	1 analog RGBHV, RGBS, RGsB, component video, or S-video; or 1 S-video and 1 NTSC/PAL/SECAM composite video from a single source; or 3 NTSC/PAL composite video from a single source
TP T 15HD AV	1 analog RGBHV, RGBS, RGsB, component video, or S-video; or 1 S-video and 1 NTSC/PAL/SECAM composite video from a single source; or 3 NTSC/PAL/SECAM composite video from a single source and 1 NTSC/PAL/SECAM composite video
TP T BNC DA4	1 analog RGBHV, RGBS, RGsB, component video, or S-video; or 1 S-video and 1 NTSC/PAL/SECAM composite video from a single source; or 3 NTSC/PAL/SECAM composite video from a single source
Connectors	
TP T 15HD A, TP T 468 ...	(1) 15-pin HD female (Mac and Sun/SGI to VGA adapters are available)
TP T 15HD AV	(1) 15-pin HD female (Mac and Sun/SGI to VGA adapters are available) 1 RCA female
TP T BNC DA4	5 BNC female
Nominal level	1.0 Vp-p for Y of component video and S-video, and for composite video 0.7 Vp-p for RGB and for R-Y and B-Y of component video 0.3 Vp-p for C of S-video
Minimum/maximum level(s) ...	0.3 V to 1.45 V p-p, no offset at unity gain
Impedance	75 ohms
Horizontal frequency	15 kHz to 130 kHz
Vertical frequency	30 Hz to 150 Hz

Video output — Refer to the *TP Receivers Family User's Manual*.

Audio

Number/signal type	1 or 2 sets of analog proprietary signals
Connectors	1 or 2 RJ-45 female
Frequency response	20 Hz to 20 kHz, ± 0.05 dB
THD + Noise	0.03% @ 1 kHz, 0.3% @ 20 kHz at nominal level
S/N	>63 dB at the rated maximum output
Crosstalk	<-80 dB @ 1 kHz, fully loaded
Stereo channel separation	>80 dB @ 1 kHz
CMRR	>33 dB @ 20 Hz to 20 kHz

Audio input

Number/signal type	
TP T 15HD A, TP T 468 ...	1 stereo, unbalanced
TP T 15HD AV	2 stereo, unbalanced
Connectors	
TP T 15HD A, TP T 468 ...	(1) 3.5 mm mini jack
TP T 15HD AV	(1) 3.5 mm mini jack, 2 female RCA
Impedance	5k ohms, unbalanced, DC coupled
Nominal level	-10 dBV (316 mV)
Maximum level	+5.5 dBu, (unbalanced) at 1% THD+N
CMRR	>75 dB @ 20 Hz to 20 kHz

Audio output — Refer to the *TP Receivers Family User's Manual*.

General

Power	
TP T 15 HD A, TP T 468,	
TP T 15 HD AV	15 VDC, 0.8 A, external or provided by the TP R receiver for up to 300' (91.4 m)
TP T BNC DA4	15 VDC, 0.8 A, external
NOTE	<i>The TP R 15HD A receiver does not provide power to any twisted pair transmitter.</i>
Temperature/humidity	Storage -40 to +158 °F (-40 to +70 °C) / 10% to 90%, non-condensing Operating +32 to +122 °F (0 to +50 °C) / 10% to 90%, non-condensing
Cooling	Convection, no vents

Specifications, Accessories, and Part Numbers, cont'd

Rack mount

TP T 15 HD A, TP T 15HD AV, TP T BNC DA4	Yes, with optional TP rack shelf mounting kit, part #70-123-01 (RSM 100) and the 1U, 9.5" deep rack shelf, part #60-190-01 (RSU 129) or 60-604-02 (RSB 129) Also furniture mountable with optional under-desk mounting kit, part #70-077-01 (MBU 125) or through-desk mounting kit, part #70-077-02 (MBD 129)
TP T 468	No, but wall or furniture mountable in a wall box
TP T 468 EC	No, but wall or furniture mountable in a Euro Channel raceway

Enclosure type Metal

Enclosure dimensions

TP T 15HD A, TP T 15HD AV, TP T BNC DA4	1.3" H x 6.8" W x 4.5" D (<1U high, <half rack width) (3.3 cm H x 17.3 cm W x 11.4 cm D) (Depth excludes connectors.)
TP T 468	
Plate	4.5" H x 8.3" W (4-gang) (11.4 cm H x 21.2 cm W)
Transmitter enclosure .	2.6" H x 3.1" W x 1.1" D (6.6 cm H x 7.9 cm W x 2.8 cm D) (Depth excludes front and rear panel connectors and controls.)
TP T 468 EC	
Plate	3.2" H x 7.7" W (8.0 cm H x 19.5 cm W)
Transmitter enclosure .	2.5" H x 3.7" W x 1.75" D (6.4 cm H x 9.4 cm W x 4.5 cm D) (Depth excludes front and rear panel connectors and controls.)

Product weight

TP T 15HD A, TP T 15HD AV	0.8 lbs (0.4 kg)
TP T BNC DA4	0.9 lbs (0.4 kg)
TP T 468, TP T 468 EC	0.7 lbs (0.3 kg)

Shipping weight 3 lbs (1.4 kg)

Vibration ISTA/NSTA 1A in carton
(International Safe Transit Association)

Regulatory compliances

Safety	CE, C-tick, CUL, UL
EMI/EMC	CE, C-tick, FCC Class A, ICES, VCCI
MTBF	30,000 hours
Warranty	3 years parts and labor

NOTE Specifications are subject to change without notice.

NOTE All nominal levels are at $\pm 10\%$.

Included Parts

These items are included in each order for a specific TP transmitter:

Included parts	Replacement part number
TP T 15HD A	60-345-02
<i>TP Transmitters Family User's Guide</i>	
Single output external power supply, 15 V, 0.8 A	70-057-01
Captive screw connector, 3 pole, 3.5 mm	10-265-03
TP T 15HD AV	60-346-03
<i>TP Transmitters Family User's Guide</i>	
Single output external power supply, 15 V, 0.8 A	70-057-01
Captive screw connector, 3 pole, 3.5 mm	10-265-03
TP T 468	
TP T 468 (gray)	60-434-01
TP T 468 (black)	60-434-02
TP T 468 (white)	60-434-03
TP T 468 (EC)	60-434-10
<i>TP Transmitters Family User's Guide</i>	
Single output external power supply, 15 V, 0.8 A	70-057-01
4-gang mud ring (gray, black, white)	70-086-03, -13, -23
TP T BNC DA4	60-349-02
<i>TP Transmitters Family User's Guide</i>	
Single output external power supply, 15 V, 0.8 A	70-057-01
Captive screw connector, 3 pole, 3.5 mm	10-265-03

NOTE The TP T 15HD AV is a redesigned transmitter. The audio portion of the composite video TP link can be configured to work with the similarly redesigned TP R BNC AV receiver or with older, unmodified receivers. See "Audio jumpers" in chapter 2, "Installation and Operation." Redesigned transmitters and receivers have an identifying label.

Accessories

Accessory	Part number
P/S 150 Multiple output 15V power supply	60-432-01
Extron 9.5" Deep 1U Rack Shelf kit (RSU 129)	60-190-01
Extron 9.5" Deep 1U Basic Rack Shelf (RSB 129)	60-604-02
Extron TP Rack Mounting Kit (RSM 100)	70-123-01
Extron Under Desk Mounting Kit (MBU 125)	70-077-01
Extron Through-desk Mounting Kit (MBD 129)	70-077-02
4-gang "J" box 2.5" (6.4 cm) deep	980097

Cables and Adapters

NOTE *Skew-Free™ A/V UTP cables are not recommended for Ethernet/LAN applications.*

Skew-Free™ A/V cable	Part number
UTP 23SF-4/3 — 3' (90 cm)	26-569-01
UTP 23SF-4/6 — 6' (1.8 cm)	26-569-02
UTP 23SF-4/12 — 12' (3.6 m)	26-569-03
UTP 23SF-4/25 — 25' (7.6 m)	26-569-04
UTP 23SF-4/35 — 35' (10.6 m)	26-569-05
UTP 23SF-4/50 — 50' (15.2 m)	26-569-06
UTP 23SF-4/75 — 75' (22.8 m)	26-569-07
UTP 23SF-4/100 — 100' (30.4 m)	26-569-08
UTP23SF-4P/25 — 25' (7.6 m) plenum	26-570-04
UTP23SF-4P/35 — 35' (10.6 m) plenum	26-570-05
UTP23SF-4P/50 — 50' (15.2 m) plenum	26-570-06
UTP23SF-4P/75 — 75' (22.8 m) plenum	26-570-07
UTP23SF-4P/100 — 100' (30.4 m) plenum	26-570-08
UTP23SF-4P/150 — 150'(45.7 m) plenum	26-570-09
UTP23SF-4P/200 — 200' (61 m) plenum	26-570-10
UTP23SF-4P/250 — 250' (76.2 m) plenum	26-570-11
UTP23SF-4P/300 — 300' (91.4 m) plenum	26-570-12

Specifications, Accessories, and Part Numbers, cont'd

Bulk cable	Part number
UTP23SF-4/1000 — 1000' (300 m) non-plenum	22-141-03
UTP23SF-4/1000 — 1000' (300 m) plenum	22-142-03
RJ-45 connector	Part number
CAT 6 jack (black)	100-476-01
CAT 6 jack (red)	100-477-01
CAT 6 jack (blue)	100-478-01
CAT 6 jack (orange)	10-479-01
CAT 6 jack (gray)	10-480-01
CAT 6 jack (white)	10-481-01
CAT 6 jack (ivory)	10-482-02
Assorted cables and adapters	Part number
VGA-A M-M MD/3 — 3' (90 cm) MHRA 15HD cable with audio	26-490-01
VGA-A M-M MD/6 — 6' (1.8 cm) MHRA 15HD cable with audio	26-490-02
SYM BNCf/.05 — 6" (15 cm) cable	26-531-01
MHR5 BNC/25 — 25' (7.6 m) cable	26-260-03
MHR-2 SVM-M/6 — 6' (1.8 m) cable	26-316-02
SVHSM - BNCf — 8" (20 cm) adapter	26-353-01
SVHSM - BNCM— 3' (90 cm) adapter	26-353-03

Optional Adapter Plates

A variety of optional adapter plates for pass-through connections can be ordered for the TP T 468, which can have up to four adapter plates installed. The following configurations of adapters can be installed in a TP T 468:

- Four single-space (single-height) adapter plates
- Two single-space (single-height) adapter plates and one double-space adapter plate
- Two double-space (single-height) adapter plates

The tables on the following pages list the available adapter plates.

Single Type Connector Architectural Adapter Plates												
Adapter plate description	Plate size	Front connector type	Rear connector type	Part #	Gray	Black	White					
Blank plate 1	1	n.a.	n.a.	70-090	-01	-11	-21					
Blank plate 2	2	n.a.	n.a.	70-090	-02	-12	-22					
2 BNC barrel (female to female)	1	BNC female	BNC female	70-091	-01	-11	-21					
3 BNC barrel (female to female)	1	BNC female	BNC female	70-091	-02	-12	-22					
5 BNC barrel (female to female)	2	BNC female	BNC female	70-091	-03	-13	-23					
2 RCA female to solder cups	1	RCA female (red/black)	solder lug terminals	70-092	-01	-11	-21					
3 RCA female to solder cups	1	RCA female (red/black)	solder lug terminals	70-092	-02	-12	-22					
2 RCA female barrel (female to female)	1	RCA female (red/black)	RCA female	70-093	-01	-11	-21					
3 RCA female barrel (female to female)	1	RCA female (red/black)	solder lug terminals	70-092	-02	-12	-22					
2 RCA to BNC barrel (female to female)	1	RCA female (red/black)	BNC female	70-094	-01	-11	-21					
3 RCA to BNC barrel (female to female)	1	RCA female (red/black)	BNC female	70-094	-02	-12	-22					
2 S-video to S-video barrel (female to female)	1	4-pin mini DIN female	4-pin mini DIN female	70-095	-01	-11	-21					

Specifications, Accessories, and Part Numbers, cont'd

2 F connector barrel	1	F connector female	F connector female	70-096	-01	-11	-21
2 ¼" stereo phono female	1	¼" stereo phono female	3 solder lug terminals	70-097	-01	-11	-21
2 ¼" stereo phono female	1	¼" stereo phono female	2 solder lug terminals	70-097	-21	-21	-22
2 3.5 mm mini stereo female	1	3.5 mm mini stereo female	3 solder lug terminals	70-098	-01	-11	-21
2 RJ-11 (female to terminal post)	2	RJ-11 female	RJ-11 terminal post	70-099	-01	-11	-21
2 RJ-45 (female to female)	2	RJ-45 female	RJ-45 female	70-100	-01	-11	-21
1 HD-15 (female to female)	1	15-pin HD female	15-pin HD female	70-101	-01	-11	-21
1 HD-15 (male to male)	1	15-pin HD male	15-pin HD male	70-101	-02	-12	-22
1 D-9 (female to female)	1	9-pin D female	9-pin D female	70-102	-01	-11	-21
1 D-9 (male to male)	1	9-pin D male	9-pin D male	70-102	-02	-12	-22
1 3-pin XLR female	2	3-pin XLR female	3 solder lug terminals	70-103	-01	-11	-21
1 4-pin XLR female	2	4-pin XLR female	3 solder lug terminals	70-103	-02	-12	-22
1 6-pin XLR female	2	6-pin XLR female	3 solder lug terminals	70-103	-03	-13	-23
2 6-pin mini DIN (keyboard/mouse)	1	6-pin mini DIN female	6-pin mini DIN female	70-104	-01	-11	-21
1 3.5 mm, 5 pole captive screw terminal	1	3.5 mm, 5 pole captive screw	solder cups	70-105	-01	-11	-21
1 contact closure switch/LED show-me and 3.5 mm stereo mini jack	1	contact closure switch and 3.5 mm mini stereo jack	solder cups	70-106	-01	-11	-21

Multi Type Connector Architectural Adapter Plates							
Adapter plate description	Plate size	Front connector type	Rear connector type	Part #	Gray	Black	White
1 S-video female and 1 RCA female	2	4-pin mini DIN female and RCA female	4-pin mini DIN female and RCA female	70-107	-01	-11	-21
1 S-video female and 3 RCA female	2	4-pin mini DIN female and RCA female	4-pin mini DIN female and RCA female	70-107	-02	-12	-22
1 S-video female and 2 RCA female	2	4-pin mini DIN female and RCA female	4-pin mini DIN female and RCA female	70-107	-03	-13	-23
1 BNC female and 2 RCA female	1	BNC female and RCA female	BNC female and RCA female	70-108	-01	-11	-21
1 BNC female and 1 3.5 mm mini stereo jack	1	BNC female and 3.5 mm mini stereo jack	BNC female and solder cup	70-108	-02	-12	-22
1 RCA female and 1 3.5 mm mini stereo jack	1	RCA female and 3.5 mm mini stereo jack	RCA female and solder cup	70-109	-01	-11	-21

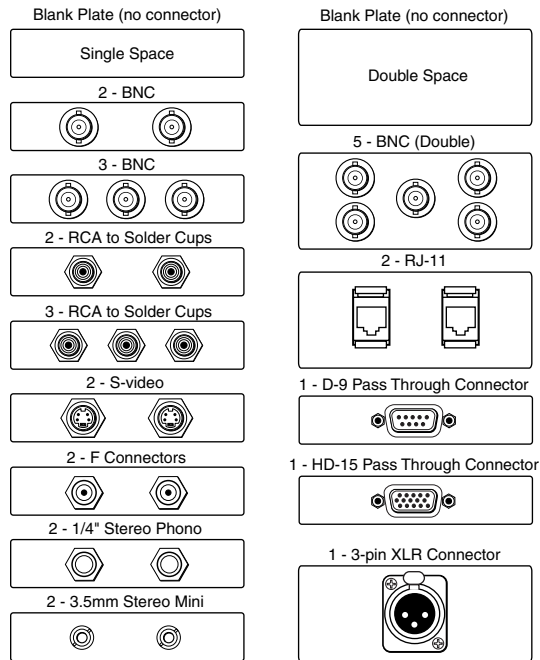

Figure A-1 — Architectural adapter plates

TP T 468 Template

The following template is actual size. It also includes the recommended 0.1" (0.25 cm) clearance on all sides of the electrical wall box to allow room for raised area surrounding the knockout.

The dashed line on the template indicates the cut-out area for installing a wall box. If you plan to install the TP T 468 without a wall box, use the smaller cut-out area indicated by the dotted lines.

Use the following template as a guide for cutting a hole in a wall or furniture for the 4-gang size electrical box in order to install the transmitter.

